

# Natural Refrigerants in Iran; Country Situation, Applications and Experiences

**Farzad Jafarkazemi**

Associate Professor, Islamic Azad University

Vice Chairman, Iranian Society of Energy Consumption Management

Board Member, Iranian Society of Heating and Refrigeration

Chillventa, October 2018

**euramm<sup>o</sup>n**  
refrigerants delivered by mother nature

- ❑ Previous accomplishment and contribution to CFC, HCFC phase down
- ❑ Current statues regarding Kigali amendment
- ❑ Sector-wise natural refrigerant application in Iran
- ❑ Natural refrigerants availability and application
- ❑ Final comments



## 1. Contribution to CFC phase-out

Iran joined the Vienna Convention and the Montreal Protocol in 1994.  
Partnership with the international agencies such as UNDP, UNIDO  
and UN Environment and the support from the Government of Germany.



# 1. Contribution to CFC phase-out (ODS phase out schedule versus ODS phased out)

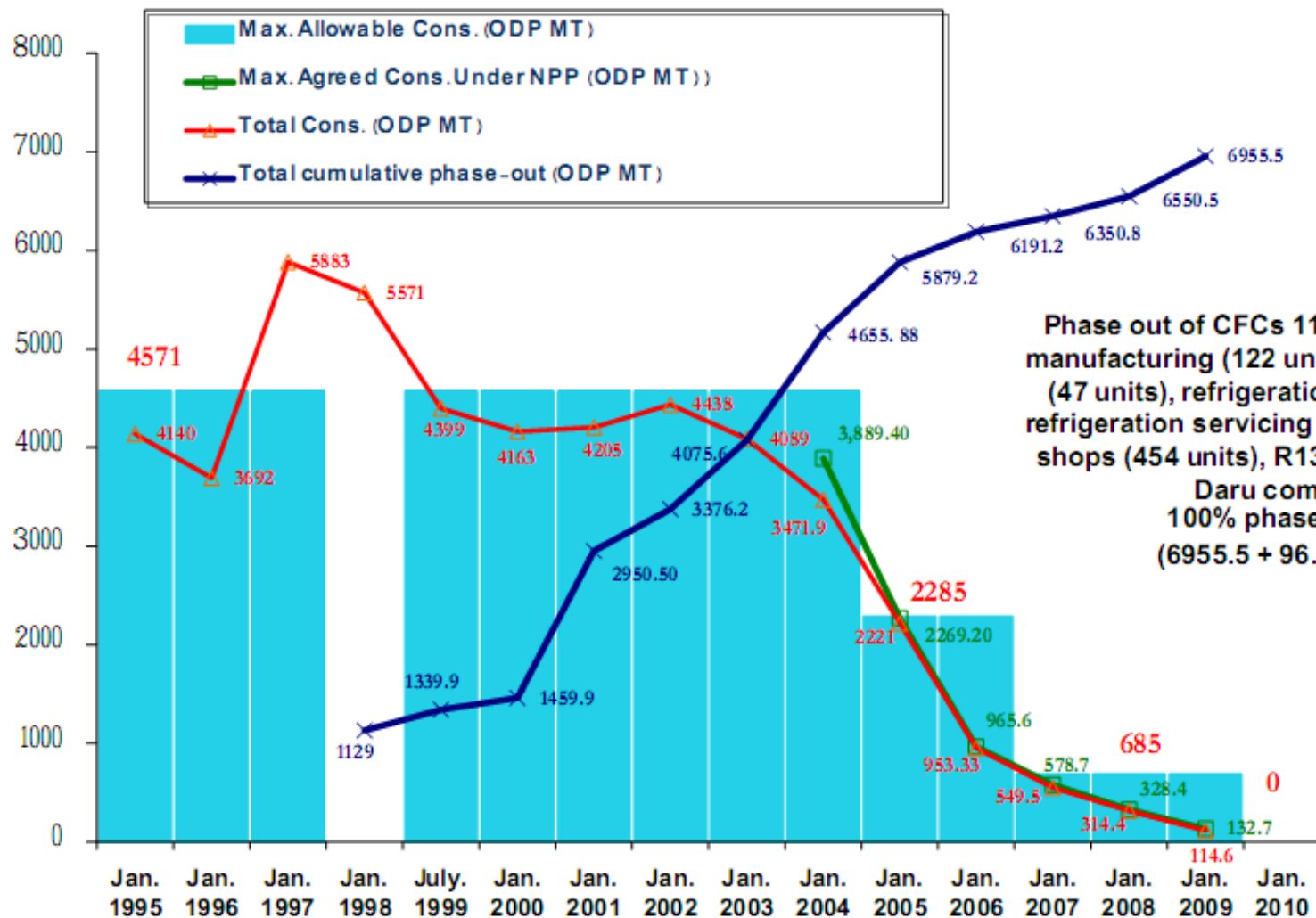

Phase out of CFCs 11 and 12 in refrigeration manufacturing (122 units), foam manufacturers (47 units), refrigeration assembly (66 units), refrigeration servicing (595 units), MAC service shops (454 units), R133 user (1 unit) and Sina Daru company (1 unit)  
 100% phase-out of CFCs  
 (6955.5 + 96.4 = 7051.9 MT)

Source: Department of Environment of Iran (National Ozone Unit)

# Phase out the CFC → Increasing use of HCFC and HFC (World Trend)

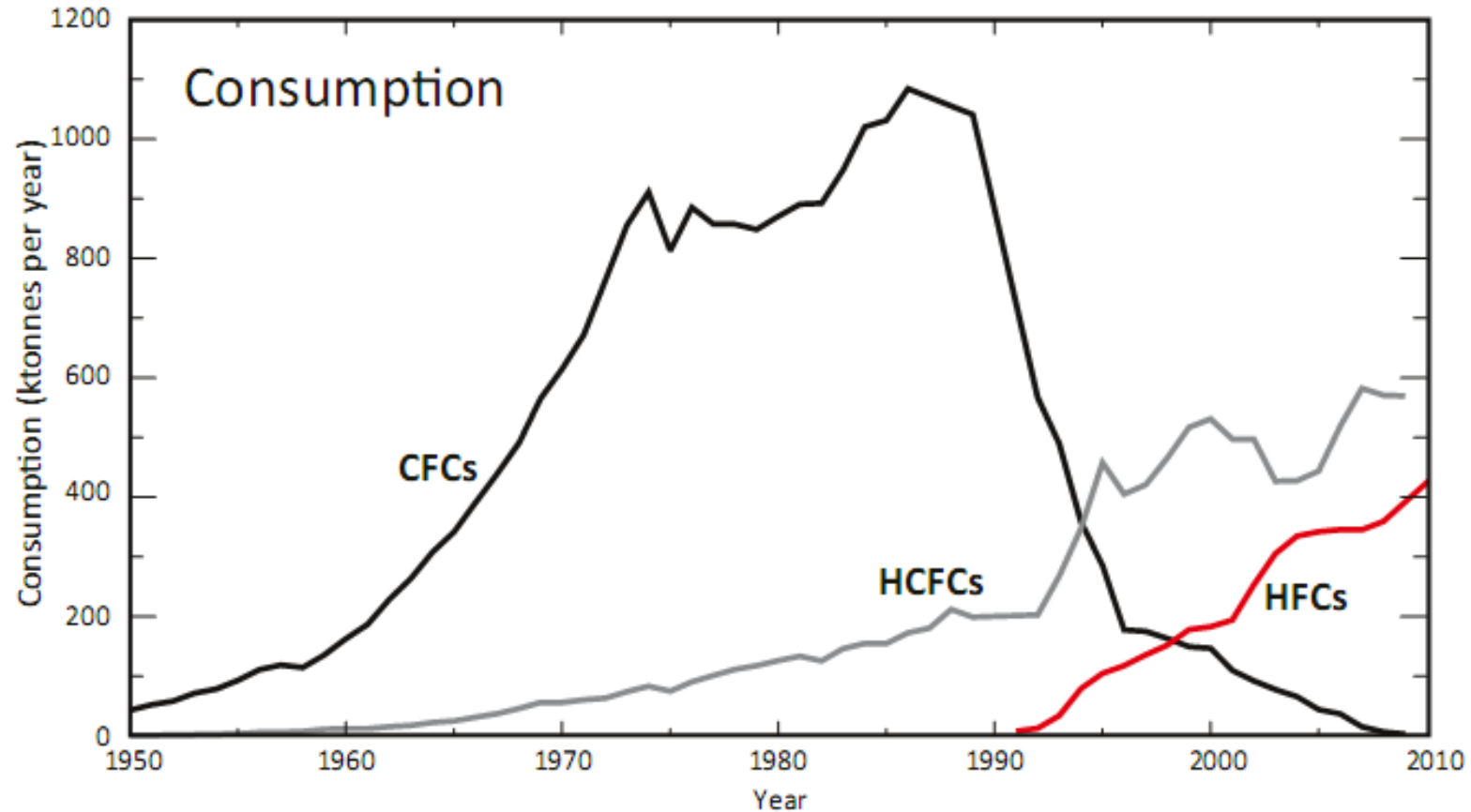

**Source:** HFCs: A Critical Link in Protecting Climate and the Ozone Layer, UNEP, 2011

# Phase out the CFC → Increasing use of HCFC and HFC (Iran trend)

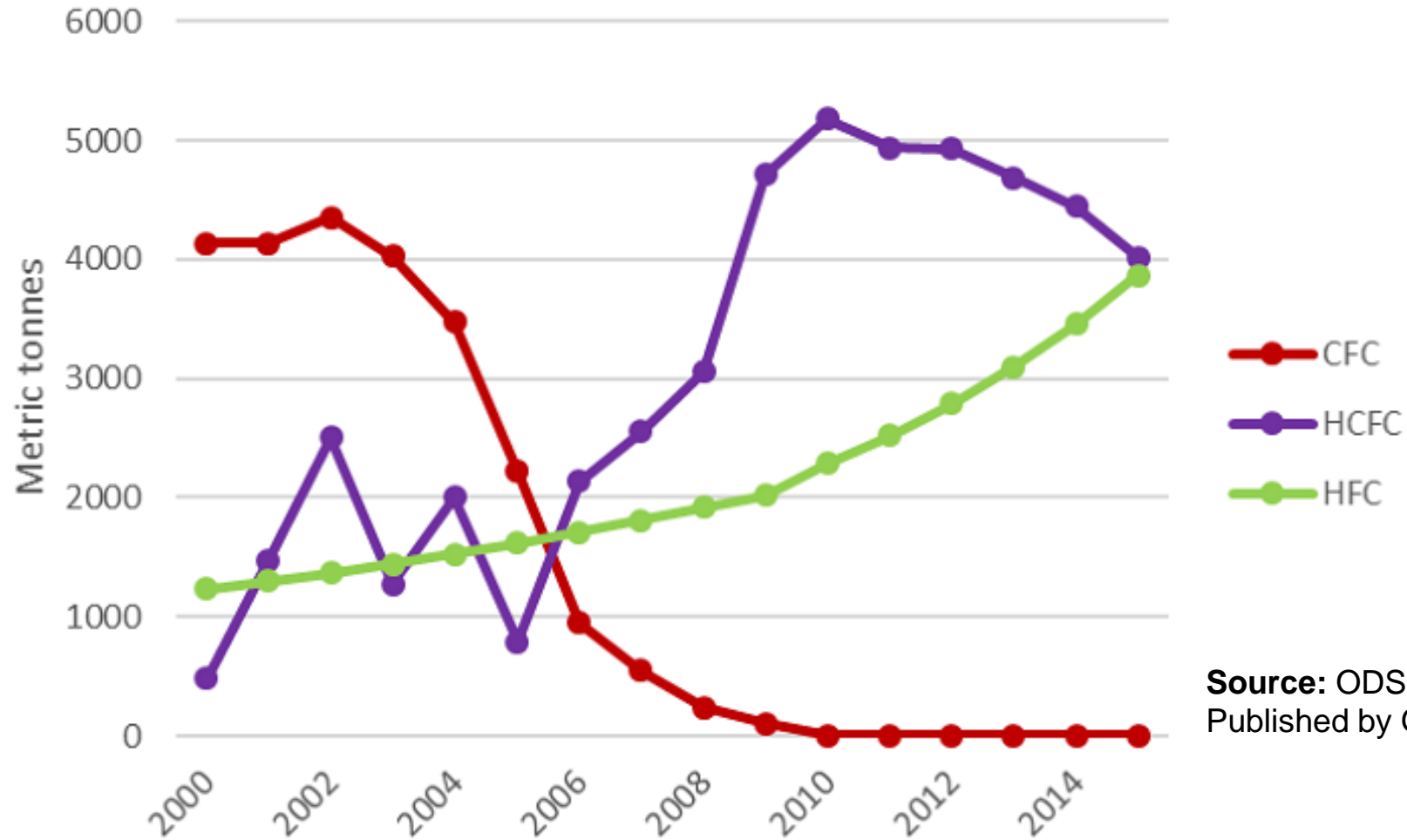

**Source:** ODS bank inventory, Islamic Republic of Iran  
Published by GIZ, September 2018



## 2. Contribution to HCFC phase-out

Following the success in CFC phase-out, a partnership between the UN and Iran has started since 2012 to phase-down HCFC under Hydrofluorocarbons Phase-Out Management Plan (HPMP).

As a Party to the Montreal Protocol, Iran must incrementally decrease HCFC consumption culminating in a complete HCFC phase-out in 2030.

### **Supporting Mechanism**

**The Multilateral Fund (MLF) for the Implementation of the Montreal Protocol**

# Contribution to HCFC phase-out

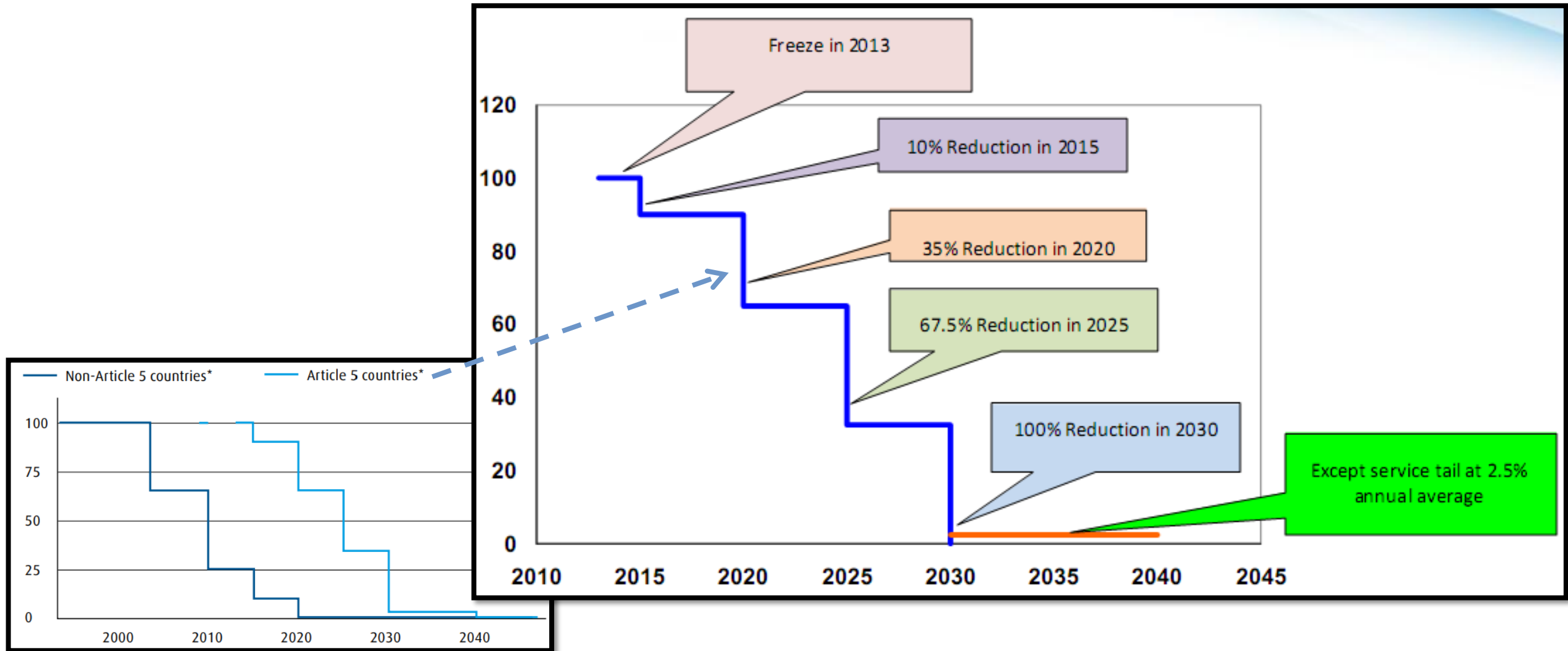



## 2. Contribution to HCFC phase-out

### What have been accomplished so far:

- ❑ Achievement of Iran's HCFC compliance targets: freeze at baseline consumption level (380.5 ODP tons) by 2013 and 10% reduction of the baseline (342.5 ODP tons) by 2015.
- ❑ Technology transfer through conversion projects in HCFC-consuming sectors including projects in residential-air conditioners, foam and refrigeration sectors and providing training in the servicing sector resulting in the phase-out of about 164 ODP tons of HCFCs.
- ❑ Establishing and enforcement of a national licensing and quota system under the Montreal Protocol's commitments to control and reduce consumption of HCFCs.
- ❑ Several training and awareness workshops have been held to train technicians on good practices in the refrigeration and air –conditioning sectors.
- ❑ Approval of HCFCs phase-out Management Plan(HPMP) second and final stage to reduce 162 ODP tons of HCFCs.

## 2. Contribution to HCFC phase-out

### Some important points:

- ❑ Iran is a consumer of HCFCs and there is no production facility within the country
- ❑ R22 is the main common HCFC refrigerant in Iran which is being used in commercial and industrial refrigeration, RAC and chillers.
- ❑ Phase plans for HCFC phase out may have different effects on HFC use in future
- ❑ Iran accomplishments regarding phase-out of HCFC and Phase-down HFCs are not as fast as expected.

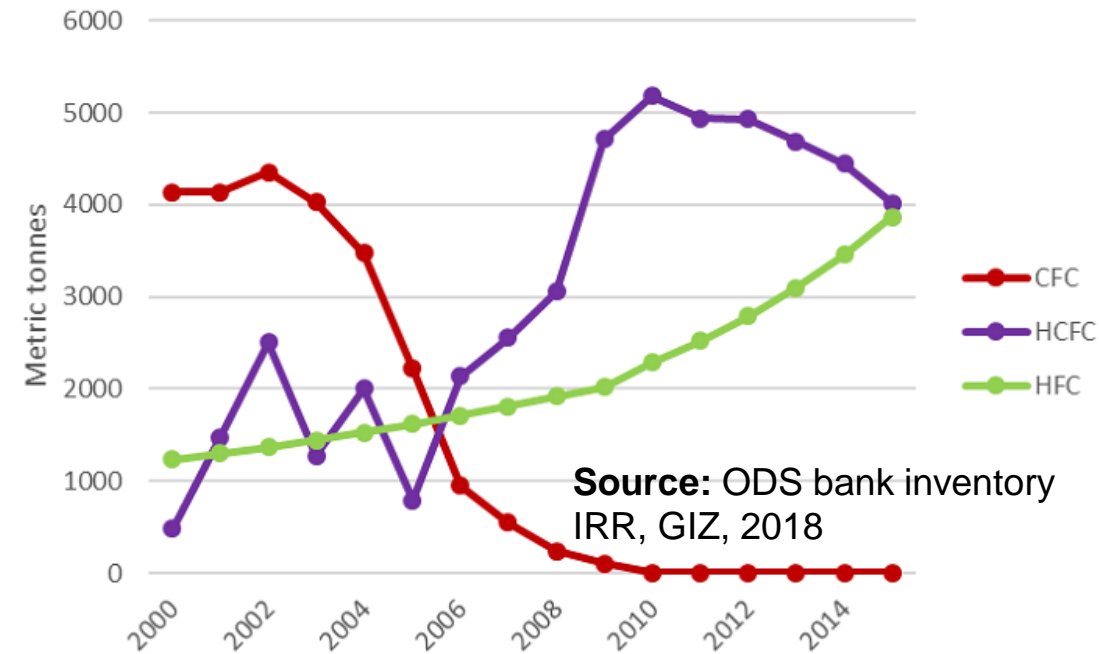

### 3. Contribution to Kigali Amendment

Kigali Amendment to the Montreal Protocol on Substances that Deplete the Ozone Layer.  
Adopted by the 28th MOP to the Montreal Protocol on 15 October 2016 in Kigali, Rwanda.



IRAN, among some other hot countries including:  
Bahrain, India, Iraq, Kuwait, Oman, Pakistan, Qatar, Saudi Arabia, and the United Arab Emirates  
will freeze HFCs use by **2028**.

## Phase-down schedule for HFCs in Article 5 and non-Article 5 parties

	<b>A5 parties (developing countries) - Group 1</b>	<b>A5 parties (developing countries) - Group 2</b>	<b>Non-A5 parties (developed countries)</b>
<b>Baseline formula</b>	Average HFC consumption levels for 2020-2022 + 65% of hydrochlorofluorocarbon (HCFC) baseline	Average HFC consumption levels for 2024-2026 + 65% of HCFC baseline	Average HFC consumption levels for 2011-2013 + 15% of HCFC baseline*
<b>Freeze</b>	2024	2028	-
<b>1<sup>st</sup> step</b>	2029 – 10%	2032 – 10%	2019 – 10%
<b>2<sup>nd</sup> step</b>	2035 – 30%	2037 – 20%	2024 – 40%
<b>3<sup>rd</sup> step</b>	2040 – 50%	2042 – 30%	2029 – 70%
<b>4<sup>th</sup> step</b>			2034 – 80%
<b>Plateau</b>	2045 – 80%	2047 – 85%	2036 – 85%



# HAT Countries

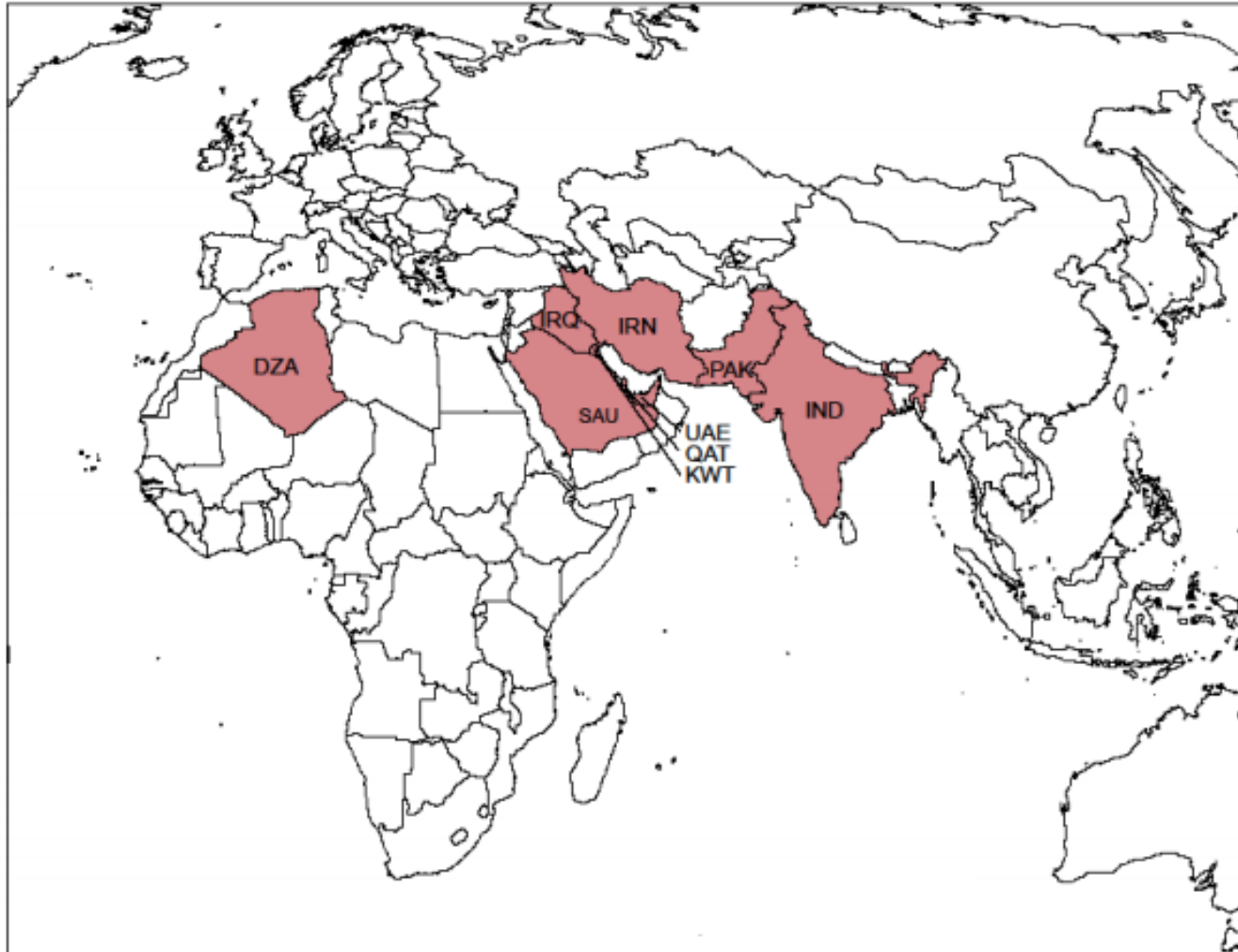

Challenges for HAT countries:

- ❑ Higher cooling loads
- ❑ Higher condensing temperature than the milder climates

**Source:** An Example High Ambient Temperature (HAT) Definition for the Montreal Protocol, Alexander Hillbrand, NRDC Geneva, 5 April 2016

# Peak power consumption in Iran

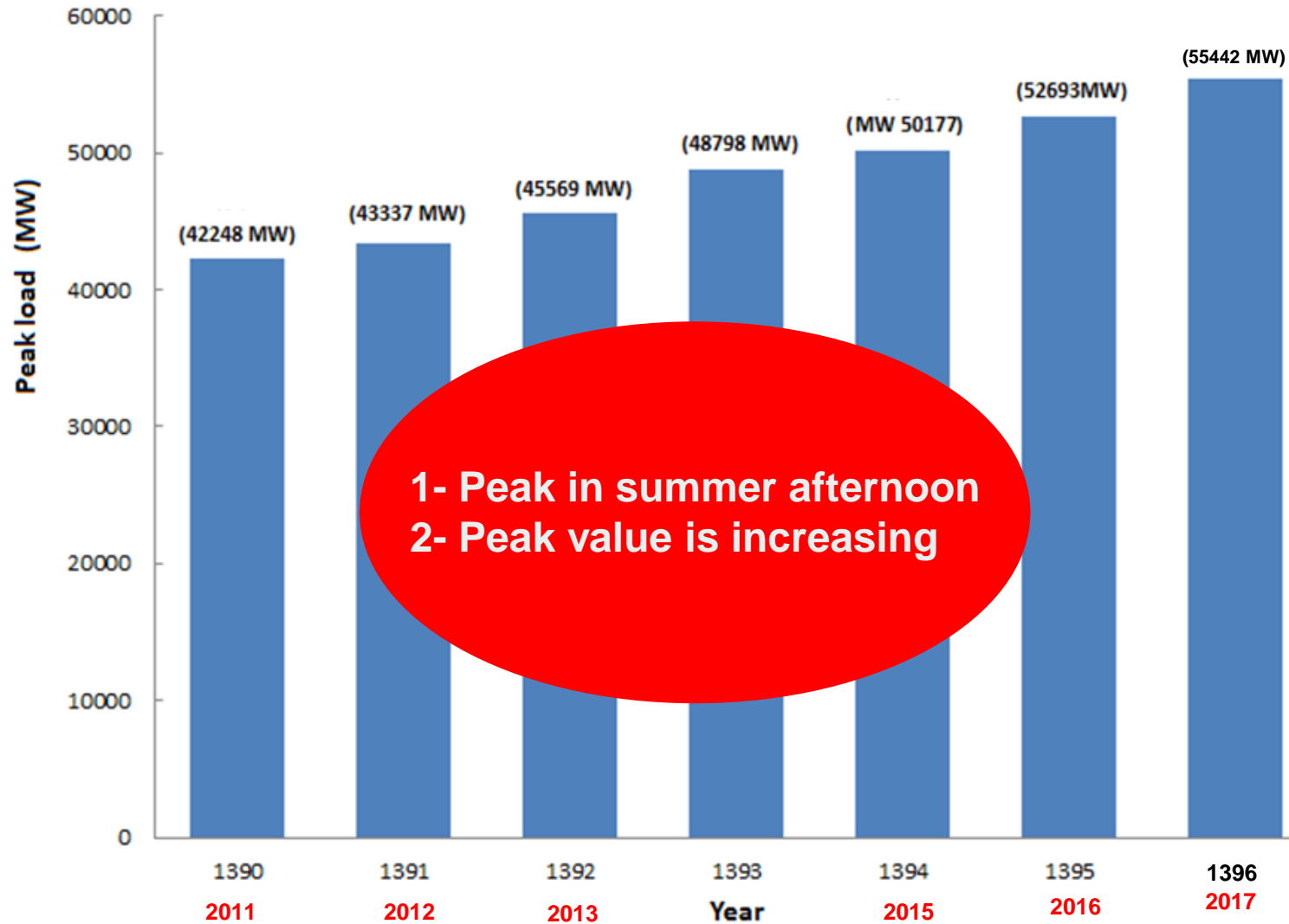

Source: <http://amar.tavanir.org.ir>

# HFC phase down schedule for article 5 countries

## High Ambient Temperature (HAT) exemption

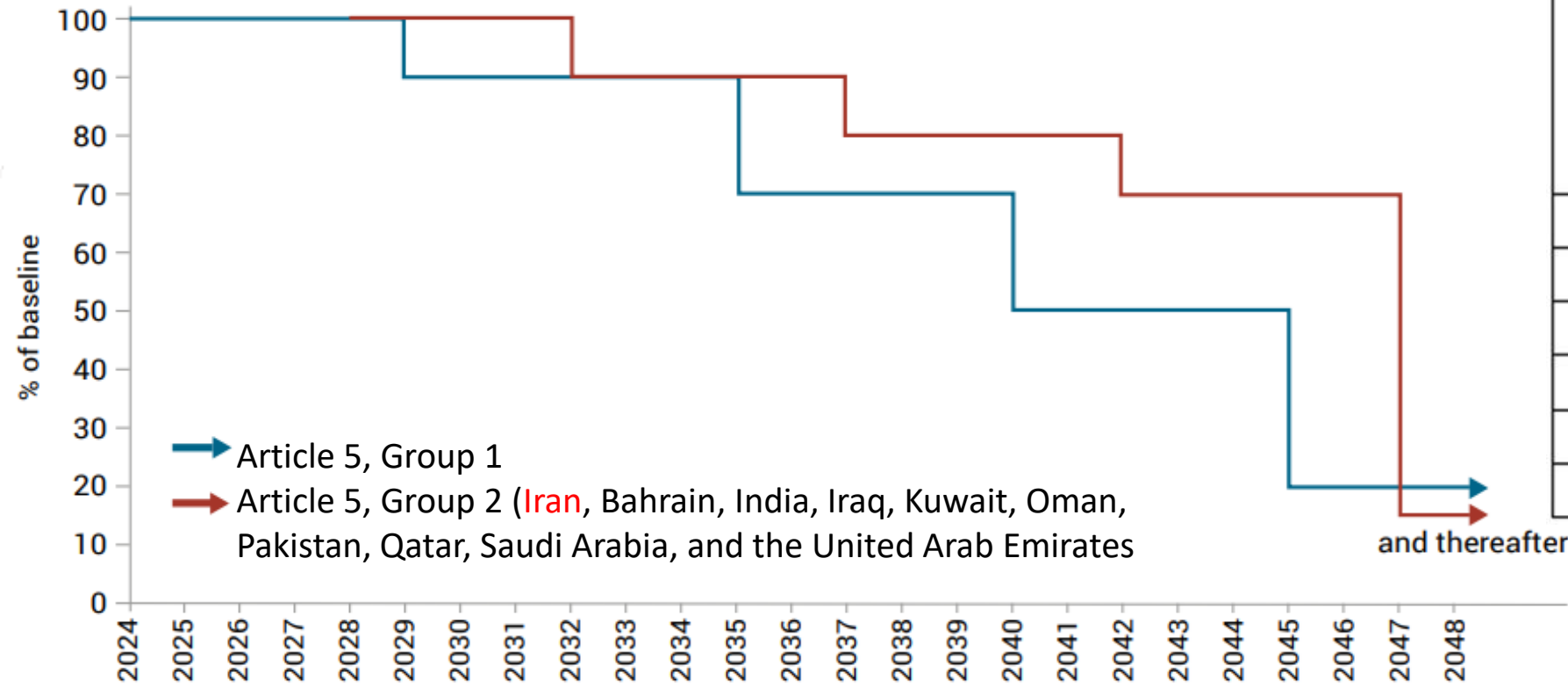

	A5 parties (developing countries) - Group 2
<b>Baseline formula</b>	Average HFC consumption levels for 2024-2026 + 65% of HCFC baseline
<b>Freeze</b>	2028
<b>1<sup>st</sup> step</b>	2032 – 10%
<b>2<sup>nd</sup> step</b>	2037 – 20%
<b>3<sup>rd</sup> step</b>	2042 – 30%
<b>4<sup>th</sup> step</b>	
<b>Plateau</b>	2047 – 85%

# BAU and MIT scenarios of HFC consumption and Kigali schedule

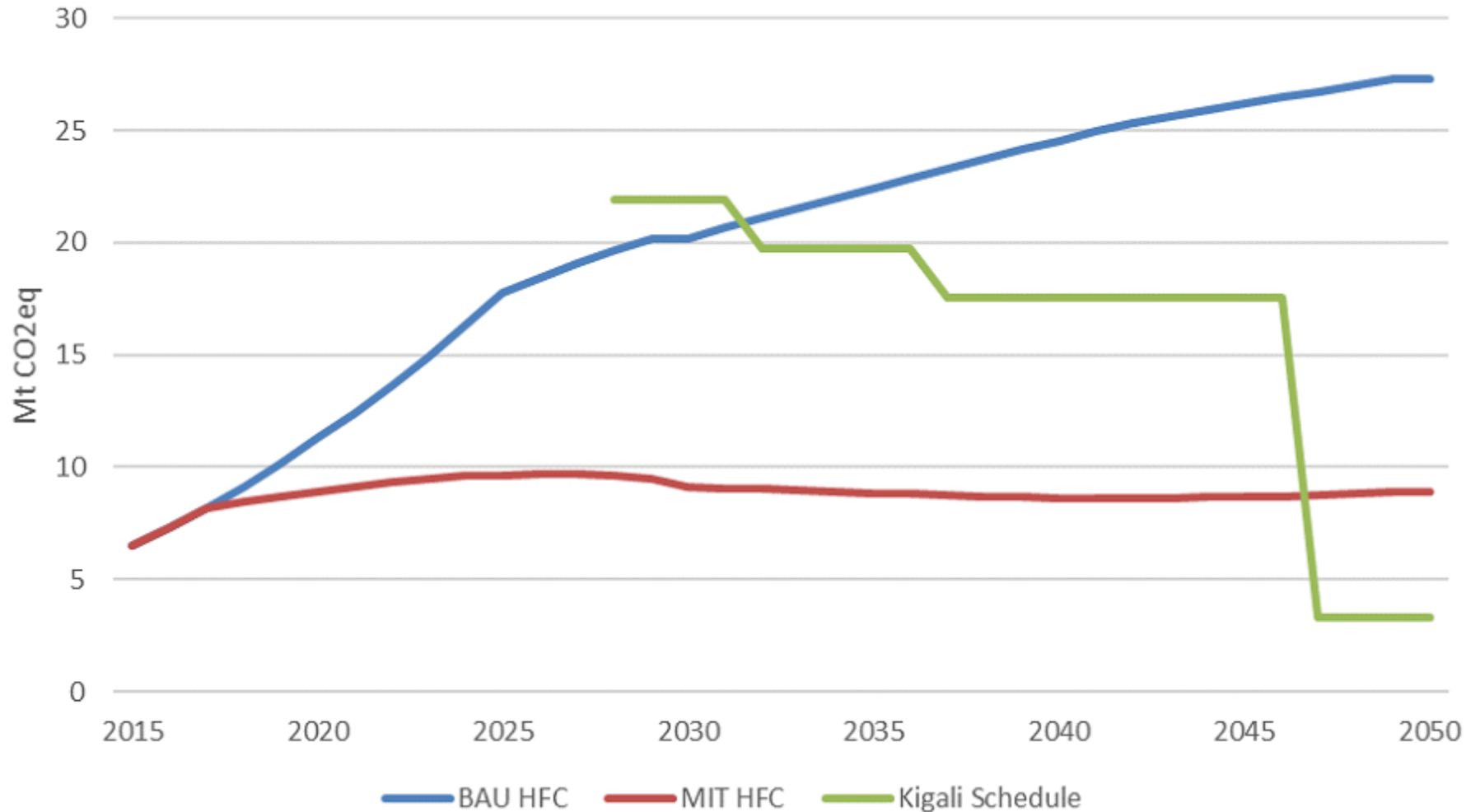

**Source:** Refrigeration and air conditioning greenhouse gas inventory for Iran  
Published by GIZ, September 2018



## Ratification statues in Iran

Country	Signature Vienna Convention	Signature Montreal Protocol	Vienna Convention	Montreal Protocol	London Amendment	Copenhagen Amendment	Montreal Amendment	Beijing Amendment	Kigali Amendment
<b>TOTALS</b>	28	46	197	197	197	197	197	197	53
Iran (Islamic Republic of)	-	-	1990-10-03 Ac	1990-10-03 Ac	1997-08-04 At	1997-08-04 At	2001-10-17 At	2013-02-14 At	Pending

Source: <http://ozone.unep.org/countries/ratifications>

## Refrigerant application in Iran; Common practice at present

	CFC	HCFC	HFC	HFO	Natural Refrigerants
Unitary air conditioning		HCFC-22	HFC-410A, HFC-407C, HFC-32		
Chillers		HCFC-22	HFC-134a, HFC-407A, HFC-407C		
Mobile air conditioning			HFC-134a	HFO-1234yf (Only some imported cars)	
Domestic refrigeration			HFC-134a		Isobutane
Commercial refrigeration		HCFC-22	HFC-134a, HFC-404A		
Industrial refrigeration		HCFC-22	HFC-404A		Ammonia
Transport refrigeration		HCFC-22	HFC-134a		

## Sector wise Natural Refrigerant application in Iran; Unitary AC

### Unitary AC

- Self contained AC
- Split AC
- Ducted Split
- Multi Split
- VRF
- Specialized systems

- Limited local manufacturers
- Products mainly imported from China and south Korea
- Illegal imports is common
- Huge boom in market
- National standards for MEP for imports ...
- Field tests are planned for R290 splits under responsibility of GIZ (Under C4 Project)



## Unitary AC

- Self contained AC
- Split AC
- Ducted Split
- Multi Split
- VRF
- Specialized systems  
(Ammonia-water AC)**



Source: <http://www.arvandcorp.com>



## Unitary AC

- Self contained AC
- Split AC
- Ducted Split
- Multi Split
- VRF
- Specialized systems  
(Evaporative Coolers)**



## Sector wise Natural Refrigerant application in Iran; Mobile AC

- ❑ Two main local manufacturers(80% market share)
- ❑ No plan for using natural refrigerants within local manufacturers for local market
- ❑ Possible future plan for natural or HFO refrigerants for some international markets
- ❑ Imported cars from China, South Korea, Japan and Europe
- ❑ The service market is going to become familiar with HFO refrigerant R1234yf for some new imported cars





## Domestic Refrigeration

- ❑ Quite a lot of local manufacturers (40% market share)
- ❑ R134a is still the main refrigerant used
- ❑ 3 manufacturers changed the production line to R600a under governmental support
- ❑ At least 3 others followed by own investment
- ❑ Imports are mainly from China and South Korea (60% market share)
- ❑ Almost all imported products use R600a
- ❑ Lack of serviceman training



## Commercial Refrigeration

- ❑ A growing sector within the past 10 years
- ❑ inefficient DX system is common
- ❑ Huge potential for energy saving
- ❑ Huge potential for charge reduction
- ❑ Huge potential for non-DX technologies
- ❑ Moderate potential for natural refrigerants
- ❑ Field tests are planned for some sample CO2 supermarket systems under responsibility of GIZ (Under HPMP Project)





# Sector wise Natural Refrigerant application in Iran; Industrial Refrigeration

## Industrial refrigeration

- Cold storages
- Process cooling
- Liquefaction plants



Photo : Aboolfazi Arab Javadi

FARS NEWS AGENCY



Source: <http://nikbh.ir>

# Sector wise Natural Refrigerant application in Iran; Industrial Refrigeration

## Industrial refrigeration

- Cold storages
- Process cooling
- Gas refineries



- A long history of Ammonia refrigeration and practice in the country
- Ammonia has a good reputation within the country, specially in large plants
- Almost half of the cold storage capacity is covered by Ammonia plants
- All of the ice producing plants work with Ammonia
- No plant with CO<sub>2</sub>, HC or CO<sub>2</sub> cascade refrigeration
- Future potential for CO<sub>2</sub>, HC or CO<sub>2</sub> cascade refrigeration

## Industrial refrigeration

- Cold storages

- Process cooling**

- Gas refineries

- A small number of dairy plants in the country use cascade CO<sub>2</sub>/Ammonia refrigeration
- Lack of awareness
- Lack of sufficient experience
- Price



# Sector wise Natural Refrigerant application in Iran; Industrial Refrigeration

## Industrial refrigeration

- ❑ Cold storages
- ❑ Process cooling
- ❑ **Gas refineries**

- ❑ Iran Holds Some Of World's Largest Deposits Of Proved Oil And Natural Gas Reserves
- ❑ Gas refineries
- ❑ Petrochemical plants



# Sector wise Natural Refrigerant application in Iran; Transport Refrigeration

## Transport refrigeration

- ❑ No background on natural refrigerant use
- ❑ HFC-134a is the dominant refrigerant. Limited use of HCFC-22 and HFC-404A.





# Summary of real practice on natural refrigerant use in Iran

	CO2	Ammonia	HC			Air	Water
			R600a	R290	Others		
Unitary air conditioning				Sample test systems			
Chillers							
Mobile air conditioning							
Domestic refrigeration							
Commercial refrigeration							
Industrial refrigeration	Limited use				Gas refineries		Ejector system
Transport refrigeration							

# Total projected bank of natural refrigerants from 2015 to 2025

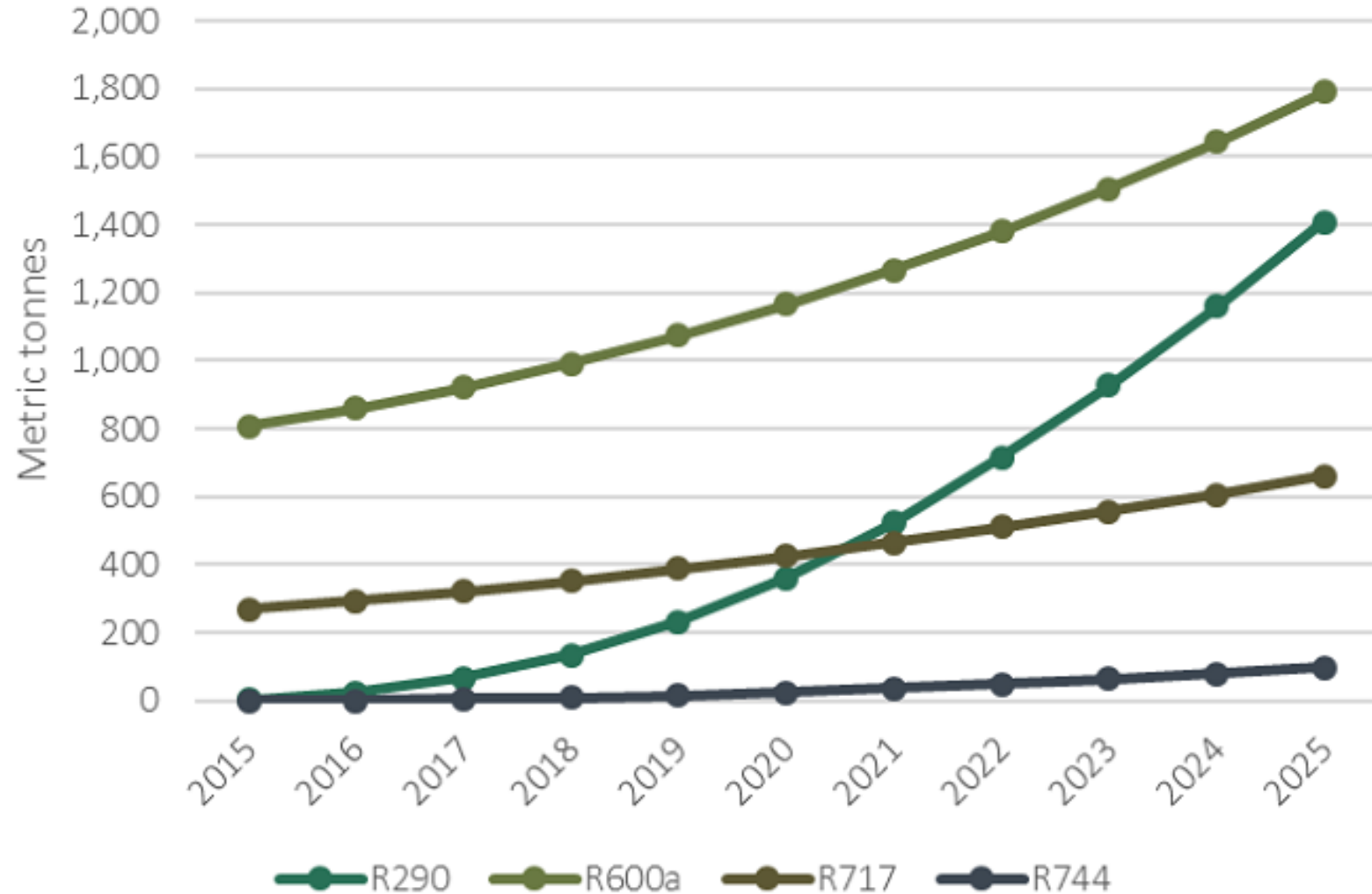

**Source:** ODS bank inventory, Islamic Republic of Iran  
Published by GIZ, September 2018

## Natural refrigerants availability and application – CO2

- ❑ Approximately 60 Production plants in Iran
- ❑ Modifications for refrigerant grade production may be needed
- ❑ Almost no best practice experience
- ❑ Lack of awareness
- ❑ Lack of technical know how
- ❑ Price of the system
- ❑ Price of the components
- ❑ High-Pressure Challenges





# Natural refrigerants availability and application – CO<sub>2</sub>

CO<sub>2</sub> from reformer chimney, Kermanshah Petrochemical



Source: <http://scdco2.com>

CO<sub>2</sub> extraction from Besat power plant





## Natural refrigerants availability and application – Ammonia

- ❑ Local production plants in Iran (Urea-Ammonia Petrochemical Plants)
- ❑ Modifications for refrigerant grade production may be needed
- ❑ A lot of previous experience
- ❑ Room for new international developments  
(dry expansion, plate HE, charge reduction, ...)
- ❑ Limited to large industrial plants
- ❑ Somewhat behind the world level progress
- ❑ Limited local experts
- ❑ Almost no university level or vocational training



Nuremberg, October 17, 2018



## Natural refrigerants availability and application – Hydrocarbons(R600a)

- ❑ Potential for local production
  - ❑ Modifications for refrigerant grade production may be needed
  - ❑ The thirst for other remaining manufacturers to follow the competitors
  - ❑ Available international experience to support local manufacturers
  - ❑ Governmental support and acceptance
  - ❑ Efficiency advantages
- 
- ❑ Still low in the market share (estimation: 20%)
  - ❑ Lack of sufficient service technician training centers
  - ❑ Safety issues
  - ❑ Standards

## Natural refrigerants availability and application – Hydrocarbons(R290)

- Potential for local production
  - Modifications for refrigerant grade production may be needed
  - Available international experience to support local manufacturers
  - Efficiency advantages over R22
  - Ongoing field test planned by GIZ (Under C4 Project)
- 
- No market available system in the country
  - Unwillingness of the importers to push it in the market!
  - No request from the market side
  - Doubts in performance improvement over R22
  - Charge limits
  - Safety issues
  - Standards

# Natural refrigerants availability and application – Hydrocarbons (other hydrocarbons)

□ Possible use in gas refineries and petrochemical plants

□ Fully imported technology (LINDE or TECHNIP)

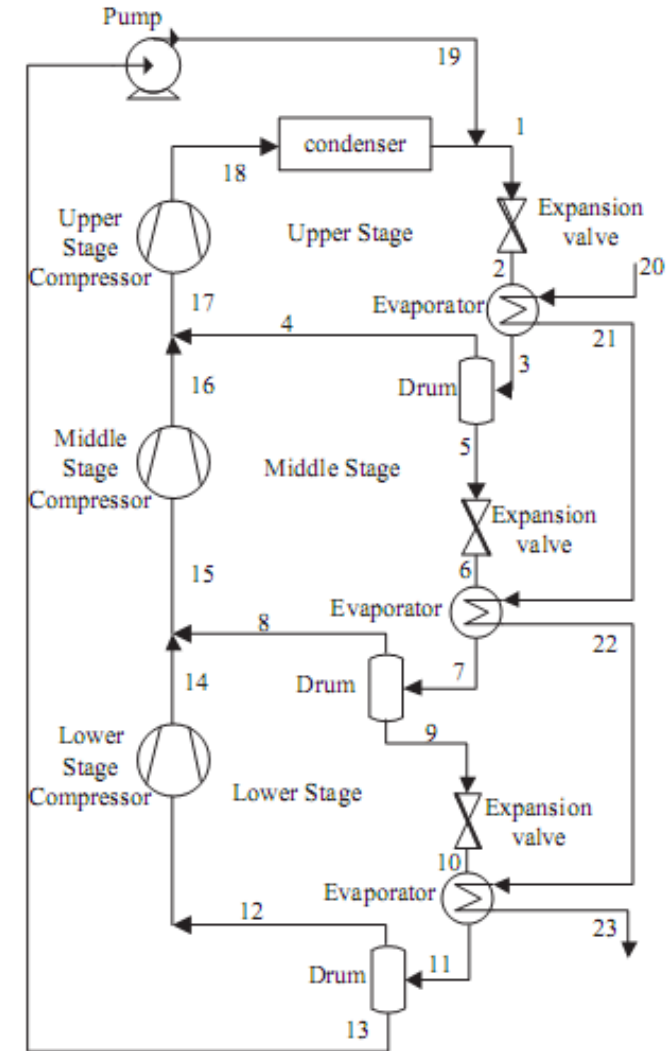
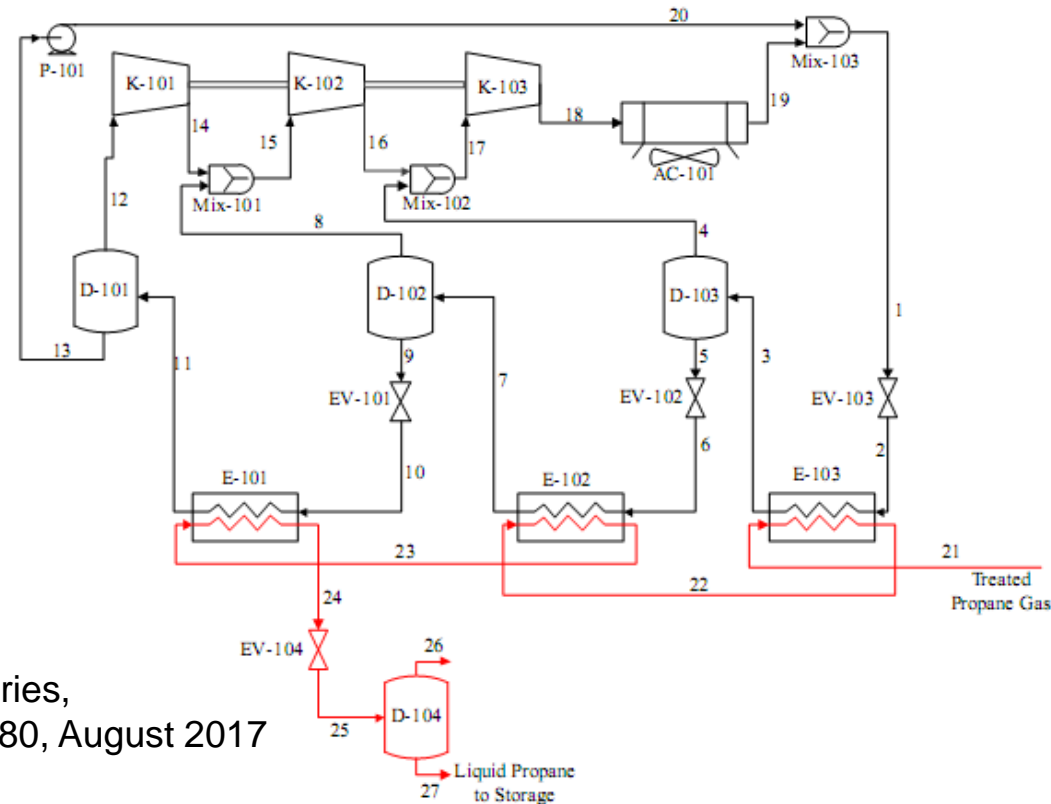

**Source:** Neyestanakia, Mafi, Ashrafizadeha, A novel approach for operational optimization of multi-stage refrigeration cycles in gas refineries, International Journal of Refrigeration, Volume 80, August 2017

### Water (As a refrigerant in ejector refrigeration system)

- ❑ Limited manufacturers and experience
- ❑ COP



Source: <http://fa.karajet.com/>

### Water (As a refrigerant in Absorption systems)

- ❑ Quite a lot of experience
- ❑ Both local manufacturers and imported products
- ❑ Natural gas as a common fuel for generator heat input
- ❑ Both indirect and direct fired system experience
- ❑ Possible combination with solar or waste heat as the energy source



Source: VIUNA HVAC&R ABSORPTION CHILLERS



### Water (As a refrigerant in Adsorption systems)

- ❑ Good potential for future use
- ❑ Possible combination with solar or waste heat as the energy source
- ❑ Limited international and local experience (limited manufacturers)
- ❑ Complex control and the importance of vacuum
- ❑ System size
- ❑ No real life experience in Iran. Limited lab experiments.



Source: Pasandideh Fard, Esmaeili, Kazemian, 2011

### Water (As a medium in evaporative cooling systems)

- ❑ Iran is a dry country (An advantage for evaporative cooling)
  - ❑ A lot of experience in the country
  - ❑ People acceptance
  - ❑ Local manufacturers (No import)
  - ❑ Price
- 
- ❑ Iran is a dry country (A disadvantage regarding water consumption)
  - ❑ Limited use in non-dry climate



photo : Hossein Zohrevand

## Water (As a medium in evaporative cooling systems)

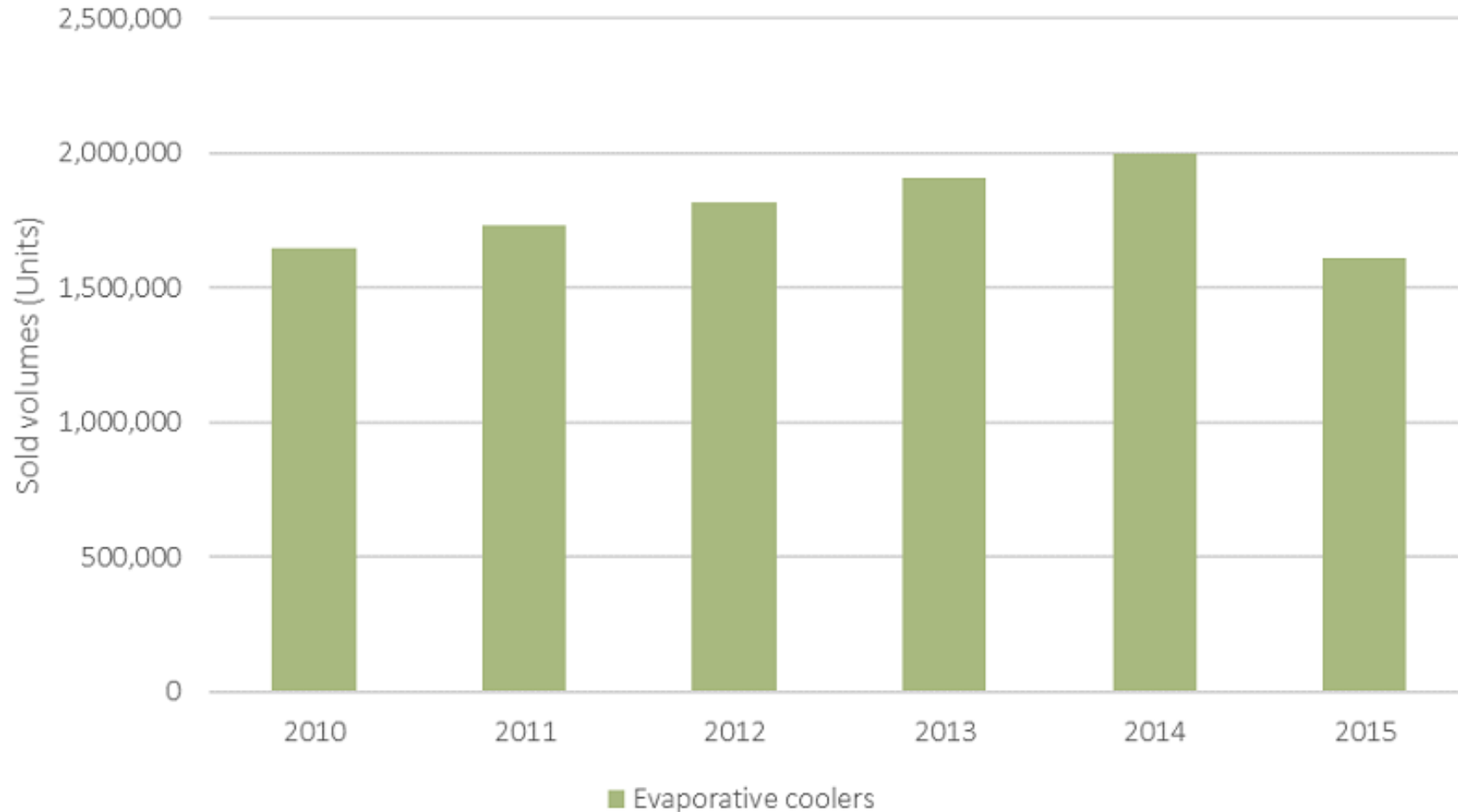

**Source:** Refrigeration and air conditioning greenhouse gas inventory for Iran  
Published by GIZ, September 2018

## Final comments to increase the market share for natural refrigerants in Iran - Opportunities

- ❑ Successful implementation of ODS phase-out in previous years brings some opportunities for the future of natural refrigerants in the country.
- ❑ Among the 5 natural refrigerants, almost none need to be imported. There is either the product available in the country or could be produced with some modification in the existing plants.
- ❑ MEPS development in Iran is pretty well linked to this Natural Refrigerants concept.
- ❑ Possible MIT ahead of Kigali schedule.
- ❑ Imported products are generally from non A5 group1 countries.
- ❑ Kigali amendment is under Montreal Protocol.



## Final comments to increase the market share for natural refrigerants in Iran - Barriers

- Lack of information on new systems using natural refrigerants (customers/suppliers/manufacturers)
- Economical aspects
- Safety issues and regulations
- Legal framework
- Multi-climate of the country from warm-humid to cold-dry which calls for special consideration when selecting a refrigerant
- Feeling of convenience, with companies continuing with 'business as usual'
- Certification system of the technicians in Iran's RAC sector and lack of this very important certification/ licensing system for the technicians who are working in the service shops (currently only the service shop owners are required, by law, to get a working license/certificate from the chambers and not those who are working in the shop)
- Investment needed to make the change
- Cost and availability of natural refrigerant based equipment and accessories)

## With special thanks to all who helped on providing this presentation:

Mr. A.A Khoobkheslat, Sarma Gostar Co. Tehran, Iran  
Mr. A. Saadatfar, Project Coordinator, GIZ office at DOE, Iran  
Mr. Z. Andjergholi, Tabadol Kar, Tehran, Iran  
Mr. Amir Radfar, iMOVE  
Dr. M. Mafi, Imam Khomeini International University, Qazvin, Iran  
Mr. A. R. Tavakoli, Renewable Energy and Energy Efficiency Organization of Iran(SATBA)  
Dr. M.H. Jalaledin Abyaneh, Viuna HVAC&R, Tehran, Iran  
Mr. M. Rahimi, Factory Manager, Sun Electronic Shahir, Tehran, Iran  
Mr. A. Mortezaia, General Cool, Tehran, Iran  
Mr. S. Ansari, Artman, Tehran, Iran  
Mr. M. S. Ahadi, Project Assistant for Iran's Third National Communication to UNFCCC (UNDP/GEF), Department of Environment, National Climate Change Office, Tehran, Iran  
Mr. H. Rezaee, SAIPA  
Mr. T. Tohid Nowdel Hokmabadi, Aclima Carbon Control  
Mr. M. Jafarzadeh Ghadimi, Djabir Sanat, Tehran, Iran  
Mr. M. Sadri Afshar, Mehad Fan, Tehran, Iran  
Mr. A. Radmanesh, Iran Technical and Vocational Training Organization  
Ms. S. Karimi, Shahrekord Carbon Dioxide Co.  
Mr. A. Seifi, Pooyesh Tahviah Co.



Thank You  
Friends of Natural Refrigerants!

**eurammon is always available as a sparring partner for questions on refrigeration with natural refrigerants.**

Contact:

Dr. Karin Jahn

Lyoner Straße 18

60528 Frankfurt

Germany

Phone: +49 (0)69 6603-1277

E-Mail: [karin.jahn@eurammon.com](mailto:karin.jahn@eurammon.com)

**eurammon**

refrigerants delivered by mother nature